

ELECTRONIC CONDENSATE DRAIN

CDi16B

DESCRIPTION

CDi16B has been developed for fully automatic discharging of condensate or any other non-aggressive fluid from compressed air⁽¹⁾ system. The unit can be installed as external drain on any application specified below. Condensate accumulates in the collecting vessel and when the level is high enough condensate is being discharged from the system without any air losses. Electronic control system has a precise capacitive level sensor through which is controlled solenoid piston valve. A special self-cleaning piston valve prevents disturbing the function of CDi16B caused by debris. CDi16B is also equipped with operation alarm, led indicator and test button.



APPLICATIONS⁽²⁾

- Air Compressor (piston or screw)
- After-cooler
- Cyclone condensate separator
- Pressure vessel/Air tank
- Air dryer
- Air filter

⁽¹⁾For any other technical gas please contact us or your local dealer

⁽²⁾CDi16B can be used in variety of applications. For applications not listed please contact us or your local dealer.

TECHNICAL SPECIFICATION

Voltage	115VAC	115 V; +/-10%
	230VAC	230 V; +/-10%
Power	115VAC	24 VA
	230VAC	24 VA
Frequency		50 – 60 Hz
Power interface		3 x 0,75mm ²
Protection class		IP54
Operating pressure	0 - 16 bar(g)	0 - 232 psi
Operating temperature	1,5 – 65°C	35 – 149 °F
Operating media	Condensate (air, water, oil); Non-aggressive	
Inlet connection	G 1/2"	
Outlet connection	G 1/8"	
Valve type	Solenoid piston valve, Normally closed	
Mass	0,95kg	
Max. Drain capacity	45l/h	0,0235scfm
Air vent option	YES	
Classification according to pressure equipment directive PED 97/23/CE (Fluid group 2)	Not required	
Directive 2004/108/EC (EMC directive)	YES	

	CDi16B ⁽⁴⁾
Peak Compressor Performance [m ³ /min]	34,8 27,9 17,4
Peak Dryer Performance [m ³ /min]	69,6 55,8 34,8
Peak Filter Performance [m ³ /min]	348 279 174
Compressor power [kW]	Up to 90

⁽⁴⁾Available in 115VAC and 230VAC versions

Climate zone:

Northern Europe, Canada, Northern USA, Central Asia
Central and Southern Europe, Central America
South East Asian coastal regions, Oceania, Amazon and Congo regions

MATERIALS⁽⁵⁾

Housing material	ABS, PA6, 30% glass fiber
Other housing parts	Steel, PA6, 30% glass fiber
Level sensor	PP (polypropylene)
Valve	Stainless Steel, brass
Sealing	NBR

⁽⁵⁾Standard version

DIMENSIONS

A	115 mm
B	85 mm
C	165 mm

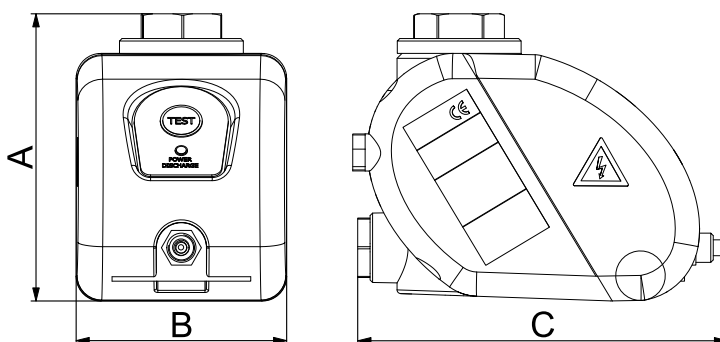

MAINTENANCE

If necessary disassemble and clean the valve. Once per year make a visual check of the drain and make sure there is no visual damage or leakage.

Condensate discharged from compressed air system contains significant amounts of lubricant oil. We strongly recommend connecting CDi16B to oil water separator. In most countries content of oil in waste water is regulated by law.

INFORMATION IN THIS DOCUMENT IS SUBJECT TO CHANGE WITHOUT NOTICE

	<p>Our quality management system is certified by BUREAU VERITAS in conformity with ISO 9001:2008 Reg. number: 200285</p>
---	--