

# ELECTRONIC CONDENSATE DRAIN – EMD HP series

## DESCRIPTION

EMD HP series drain have been developed for fully automatic discharging of condensate or any other non-aggressive fluid from compressed air<sup>(1)</sup> system. The units can be installed as external drain on any application specified below. Condensate accumulates in the collecting reservoir and when the level is high enough condensate is being discharged from the system without any air losses. Fluid level is detected by precise capacitive level sensor. Special self-cleaning direct acting valve assures reliable operating. EMD HP series is also equipped with operation alarm (version A), led indicator, test button and internal strainer. Version with Service Network (version C) for diagnostics and parameter setting is also available. Working hours, valve operations and other operating parameters are stored in internal memory and can be read with Service Network reader.



## APPLICATIONS<sup>(2)</sup>

- Air Compressor (piston or screw)
- After-cooler
- Cyclone condensate separator
- Pressure vessel/Air tank
- Air dryer
- Air filter

<sup>(1)</sup>For any other technical gas please contact us or your local dealer

<sup>(2)</sup>EMD HP series can be used in variety of applications. For applications not listed please contact us or your local dealer.

## TECHNICAL SPECIFICATION

Type	EMD HP 230V	EMD HP A 230V	EMD HP C 230V	EMD HP 115V	EMD HP A 115V	EMD HP C 115V	EMD HP 24Vac	EMD HP A 24Vac	EMD HP A 24Vdc	
Service Network Connection	No	No	Yes	No	No	Yes	No	No	No	
Alarm output	No	Yes	Yes	No	Yes	Yes	No	Yes	Yes	
Voltage	230VAC, 50 – 60 Hz			115VAC, 50 – 60 Hz			24Vac, 50 – 60 Hz		24Vdc	
Internal fuse	5X20 1A T			5X20 1A T			2A	2A		
Power	25VA			25VA			25VA		22W	
Operating pressure range	0 – 50 bar						0 – 725 psi			
Drain capacity Kv	30,4 l/h @ 50 bar, 0.018 cfm @ 725 psi						4,3 (l/h) / √bar			
Operating temperature range	1,5°C – 65°C									
Protection class	IP54									
Inlet connection	G 1/2" (parallel thread)									

Type	EMD HP 230V	EMD HP A 230V	EMD HP C 230V	EMD HP 115V	EMD HP A 115V	EMD HP C 115V	EMD HP 24Vac	EMD HP A 24Vac	EMD HP A 24Vdc
Outlet connection	G 1/4" (parallel thread)								
Mass	2.3 kg								

### Peak Compressor Capacity

The data apply for drain, which is located in the most unfavourable location i.e. compressor cyclone or pressure vessel.

System pressure	Northern Europe, Canada, Central Asia	Rest of the world	Moist tropical and subtropical regions
50 bar	29.5 m <sup>3</sup> /min	22.2 m <sup>3</sup> /min	12.9 m <sup>3</sup> /min
40 bar	26.4 m <sup>3</sup> /min	19.9 m <sup>3</sup> /min	11.5 m <sup>3</sup> /min
30 bar	22.9 m <sup>3</sup> /min	17.2 m <sup>3</sup> /min	10.0 m <sup>3</sup> /min
20 bar	18.7 m <sup>3</sup> /min	14.0 m <sup>3</sup> /min	8.1 m <sup>3</sup> /min

The amount of condensed water in compressed air system depends mainly on outside air temperature.

### PRESSURE EQUIPMENT DIRECTIVE PED 97/23/CE (Fluid group 2)

Product type	Category, module
EMD HP	Not required

### MATERIALS

Housing	
Reservoir	Aluminium
Strainer mesh	Stainless steel
Valve	Brass, Stainless steel 1.4305
Level sensor	PP (polypropylene)
Sealing	NBR

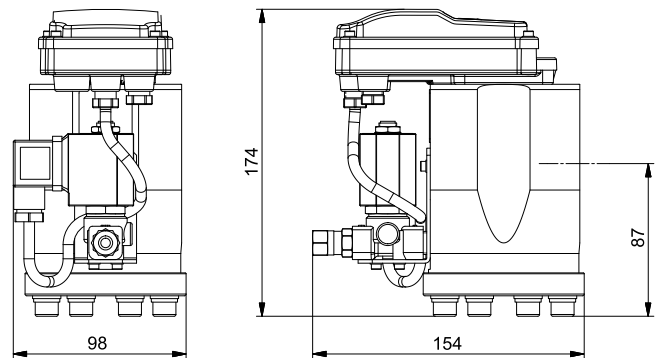

### MAINTENANCE

Once per year make a visual check of the drain and make sure there is no visual damage or leakage. Clean strainer regularly. Interval of cleaning depends on contamination of the system. All wearing parts are available as service kit.

**Condensate discharged from compressed air system contains significant amounts of lubricant oil. We strongly recommend connecting EMD HP to oil water separator. In most countries content of oil in waste water is regulated by law.**

INFORMATION IN THIS DOCUMENT IS SUBJECT TO CHANGE WITHOUT NOTICE

	Our quality management system is certified by BUREAU VERITAS in conformity with ISO 9001:2008 Reg. number: 200285
---	--