

MANUAL CONDENSATE DRAIN – Drain Valves – BV 64B

DESCRIPTION

Drain valve has been developed for manual discharging of condensate or any other non-aggressive fluid from compressed air⁽¹⁾ system. In order to prevent condensate from becoming re-entrained in the airstream we recommend controlling the condensate level in filter bowl, which requires an automatic drain trap.

⁽¹⁾ For any other technical gas please contact us or your local dealer

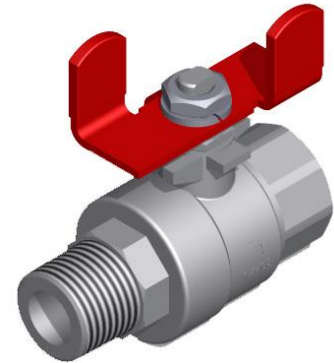

TECHNICAL SPECIFICATION

Temperature	-30 ... 180 °C	-22 ... 356 °F
Operating pressure ⁽²⁾	0 ... 64 bar(g)	0 ... 928 psi
Operating media	Condensate (air, water, oil); Non-aggressive	
Connection	BSP - ISO 7-1 Rp specifications NPT B1.20.1 specifications	
Features	Locking system	

⁽²⁾ Pressure depend on temperature. See diagramm below.

Pressure – Temperature Diagramm

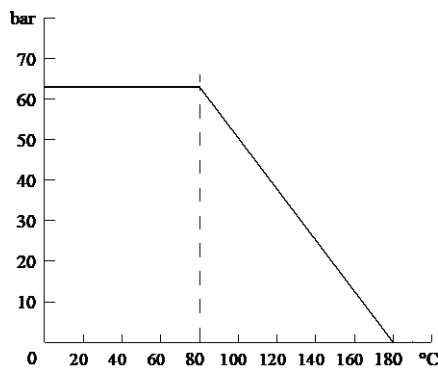

MATERIALS

Housing material	1.4408
Sealing	PTFE

PRESSURE EQUIPMENT DIRECTIVE PED 2014/68/EU

Product type	Category, module
Drain valve	Article 4.3

SIZES

VALVE SIZE – G [inch]	TYPE	DIMENSIONS [mm]					WEIGHT [kg]
		L	T	T _A	H	W _F	
1/4	BSP	57	10,5	11,5	48	45	0,18
3/8	BSP	58	10,5	12	48	45	0,19
1/2	BSP	70,5	13,5	15,5	52	50	0,24
3/4	BSP	78	13,0	17	61	60	0,40
1	BSP	91	15,5	19	65	60	0,59
1/4	NPT	66	10,5	10	48	45	0,20
3/8	NPT	66	10,5	11	48	45	0,21
1/2	NPT	83	13,5	14,5	52	50	0,29
3/4	NPT	94	13,0	16	61	60	0,45
1	NPT	105	15,5	18	65	60	0,66

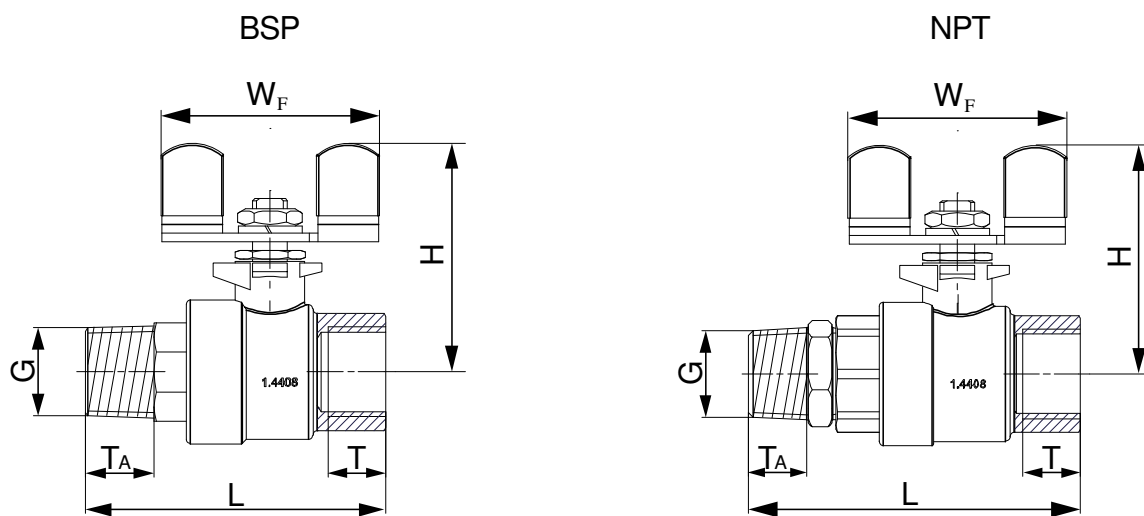

The NPT valve has an additional built-in hexagon nipple.

MAINTENANCE

Once per month make a visual check of the drain and make sure there is no visual damage or leakage. Replace the sealings if necessary.

Condensate discharged from compressed air system contains significant amounts of lubricant oil. We strongly recommend connecting Drain valve to oil water separator. In most countries content of oil in waste water is regulated by law.

INFORMATION IN THIS DOCUMENT IS SUBJECT TO CHANGE WITHOUT NOTICE

	<p>Our quality management system is certified by BUREAU VERITAS in conformity with ISO 9001:2008 Reg. number: 200285</p>	
---	--	--