

# MANUAL CONDENSATE DRAIN – MCDi

## DESCRIPTION

MCD has been developed for manual discharging of condensate or any other non-aggressive fluid from compressed air<sup>(1)</sup> system. In order to prevent condensate from becoming re-entrained in the airstream we recommend controlling the condensate level in filter bowl, which requires an automatic drain trap. MCD is easy to install on the filter housing.



## APPLICATIONS<sup>(2)</sup>

- Air filter

<sup>(1)</sup>For any other technical gas please contact us or your local dealer

<sup>(2)</sup>MCD can be used in variety of applications. For applications not listed please contact us or your local dealer.

## TECHNICAL SPECIFICATION

Operating temperature	1,5 - 120 °C	35 - 248 °F
Operating pressure	0 - 20 bar(g)	0 - 290 psi
Operating media	Condensate (air, water, oil); Non-aggressive	
Connection	G ½" (NPT option)	
Weight	0,06 kg	

## MATERIALS

Housing material	Stainless steel 1.4404
Sealing	FKM / FPM

**DIMENSIONS**

A	41 mm
B	28 mm
C	13 mm
D	G 1/2" (NPT option)
E	24 mm

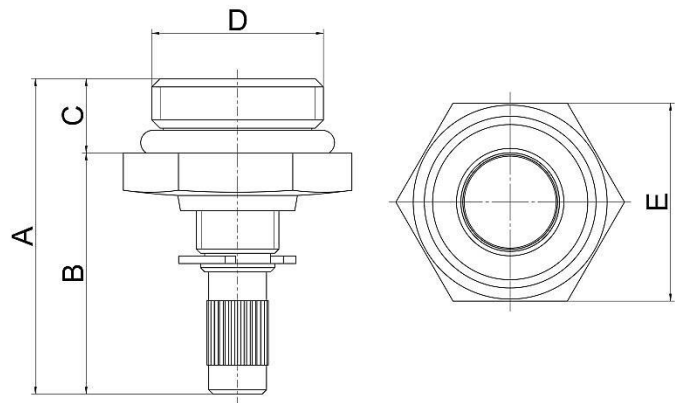

**PRESSURE EQUIPMENT DIRECTIVE PED 97/23/CE (Fluid group 2)**

Product type	Category, module
MCD	Not required

**MAINTENANCE**

Once per month make a visual check of the drain and make sure there is no visual damage or leakage. Clean interior of the filter housing regularly. Intervals of cleaning depend on contamination of condensate. Replace the sealings if necessary.

**Condensate discharged from compressed air system contains significant amounts of lubricant oil. We strongly recommend connecting MCD to oil water separator. In most countries content of oil in waste water is regulated by law.**

INFORMATION IN THIS DOCUMENT IS SUBJECT TO CHANGE WITHOUT NOTICE

	<p>Our quality management system is certified by BUREAU VERITAS in conformity with ISO 9001:2008 Reg. number: 200285</p>	
---	--	--